

SPEED CONTROL ARM AND SPINDLE KIT

The Detroit Speed control arm and spindle kit is designed to work as an integrated system to improve handling. Detroit Speed's spindle is 1-1/2" taller than the stock spindle with 2" of drop. The taller spindle height modifies the camber curve resulting in a negative camber gain during suspension compression. The stock steer arms mount in the optimal location to minimize bump steer.

The tubular control arms provide increased strength and rigidity. They come with Delrin bushings, new ball joints and have a gloss black powder coat finish. Upper control arms are designed with additional positive caster and include the cross shaft. The lower control arms feature a robust tubular design with gussets and a cross brace.

030104	1964-66, A-Body	\$2,295.00
030105	1967-72, A-Body	\$2,295.00

DSE CHEVELLE/GM A-BODY SPEED KITS

Detroit Speed's front suspension kits combine individual components into a system designed for your vehicle at three different levels. The DSE *Speed Kit 1* provides the ease of bolt-on components to improve your A-Body's handling. The *Speed Kit 2* improves the handling performance to the next level and offers ride height adjustment.

Speed Kit 1: tubular upper control arms, tubular lower control arms with stock spring pocket, Koni classic front shocks, DSE increased spring rate springs, DSE forged 2" dropped spindle DSE tubular sway bar.

Speed Kit 2: Kit #1 with single adjustable DSE coil-over conversion kit, DSE splined tubular sway bar, shock spanner tool

031309	1964-66, Speed kit 1	\$2,922.00
031310	1967, Speed kit 1	\$2,922.00
031311	1968-72, Speed kit 1	\$2,922.00
031317	1964-66, Speed kit 2	\$3,280.00
031321	1967, Speed Kit 2	\$3,280.00
031318	1968-72, Speed kit 2	\$3,280.00

All kits: must specify, SBC or LS

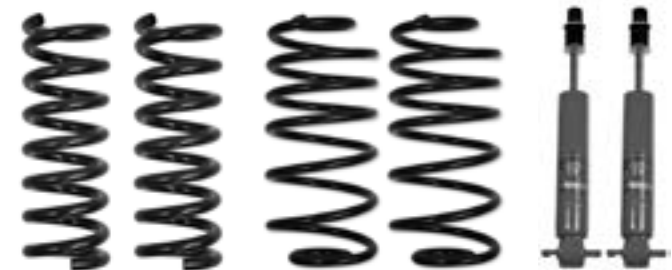

A-BODY COIL SPRINGS

Give your A-Body a modern Pro-Touring stance while improving ride and handling with DSE A-Body coil spring kits. Available in either stock ride height or a 2" drop (from stock). Rear springs give a 1-1.5" drop.

031109	1964-66, Stock (specify SB, BB, LS) . . . pair	\$285.95
031111	1968-72, Stock (specify SB, BB, LS) . . . pair	\$285.95
031109	1964-66, 2" drop (specify SB, BB, LS) .. pair	\$285.95
031111	1968-72, 2" drop (specify SB, BB, LS) .. pair	\$285.95
041802	1964-66, Rear, 1.25-1.5" drop pair	\$285.95
041804	1967-72, Rear, 1" drop pair	\$285.95

A-BODY FRONT REPLACEMENT SHOCKS

These Koni Classic rebound adjustable shocks bolt-in the stock location. They use the latest in shock absorber technology to give your car a modern feel while maintaining comfortable ride characteristics.

031007	1964-72, Stock front shocks pair	\$165.95
041306	1964-72, Stock rear shocks pair	\$165.95



1964-1972 Chevy Chevelle Suspension

1964-1972 Chevelle suspension



DSE A-BODY SWAY BARS

DSE's tubular 1-3/8" front sway kit provides a dramatic improvement on cars with stock suspension and optimal improvement on cars fitted with other DSE components. Kit includes sway bar, greaseable polyurethane bushings, mounts and end links.

The splined sway bar kit is tuned to provide the ultimate in performance, ride, and handling. It uses a 1-1/2" OD hollow 4130 alloy heat-treated splined sway bar, black hard coated 6061-T6 billet aluminum pillow blocks with Delrin bushings, 3/4" thick solid steel sway bar arms, low-friction ball style end-link system. Bolt-on 1968-72 A-Bodies; 1964-66 A-Body sway bar mounting holes need to be drilled and tapped up to 3/8".

- 031403 1964-67, Tubular sway bar \$299.00
- 031402 1968-72, Tubular sway bar \$299.98
- 031404 1964-72, Splined sway bar kit \$1,036.00

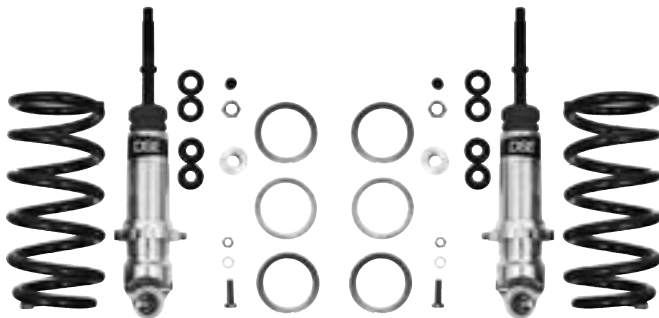

DSE FRONT COIL-OVER KIT

Now you can bolt the latest coil-over spring/shock technology to any GM A-Body. The specific DSE valving will bring your classic's handling and ride into the 21st century. The base coil-over package offers extensive ride height adjustment and special DSE valving. Optional double adjustable coil-overs offer both compression and rebound tuning. The monotube remote reservoir coil-over set is the ultimate package and offers separate fluid canisters for optimum adjustability, 1" more stroke and improved heat dissipation.

- 030306 1964-72, A-Body (specify SB, BB, LS). . . \$1,565.00
Call for pricing on shock options



HEIDTS GM A-BODY CONTROL ARMS

HEIDTS tubular upper and lower control arms for the 1964-72 Chevelle and all other GM A-body cars are state of the art in both design and fabrication. Uppers are 1-1/4" dia. tube, and the lowers are a full 1-1/2" tube. They are powder coated and completely assembled with ball joints and urethane bushings. High performance urethane bushings tighten up the suspension and allow no deflection under cornering loads for absolutely solid, positive handling. Upper arms include offset cross shafts for easier alignment and adjustment of caster settings.

- CA-401 1964-72 A-Body upper control arms \$650.00
- CA-411 1964-72 A-Body lower control arms \$995.00
- CA-411-M 1964-72 Coil-over lower control arms. . . \$995.00

Heidt's Pro-G dropped spindles (SP-110) are recommend with our control arms.

HEIDTS TALL 2" DROPPED STEEL SPINDLE

The upper ball joint is raised 1-1/2" over the factory design to yield a better camber change during suspension movement. This corrects the excessive camber change of the original design. These spindles are STEEL, the strongest ones in the industry.



- SP-110 2" Dropped Spindles pair \$470.00

QA1 COIL OVERS

Billet coil-over shocks have fully adjustable dampening. Silver powder coated full length progressive springs assure full travel and smooth ride with spring rates for small block and big block. They also fit stock lower arms using adapter kit CS-020.



- GS401 Coil-over shocks pr \$629.00
- 450# 10" Coil-over springs, smal block. . . included
- 550# 10" Coil-over springs, big block . . . included

Springs are available in 300-700 lb increments

- CQ-010 Thrust bearings for coil-over shocks \$35.00
- TA-001 Spanner wrench \$15.00



HEIDTS A-BODY SWAY BARS

Completely bolt-on with the supplied hardware.

- SB-071 1964-72 1-1/8" Chevelle front sway bar . . \$314.00
- SB-150 1964-72 1" Chevelle rear sway bar** . . . \$314.00

**Must use HEIDTS rear 4-Link package



GM-DELPHI 600 POWER STEERING GEAR

This all new steering gear replaces the common GM 800 series power steering gear used from 1964 to 1992. It uses low friction gear design and precision rack and pinion valve technology for increased steering feel. Quick ratio 12.7:1 and 6 lbs lighter than stock. Original power pitman arm may be used. A 3/4 x 30 spline rag joint and new o-ring power steering hoses are needed

- 090204** 1964-72 A-Body, ready to paint **\$695.00**
- 090204C** 1964-72 A-Body, Ceramic coated **\$780.00**
- 090205** Rag Joint, connects to stock column **\$99.00**
- 091202** Steering hose kits for 600 gear box. **\$215.00**



HEIDTS CHEVELLE REAR 4-LINKS

Tighten up the handling of your A-Body by eliminating the stock suspension flex. These upper links are adjustable, 1-1/4" dia. tube, and the lowers are a full 1-1/2" x 2" square tubing. They're powder coated black and are supplied with greaseable swivel and fixed high performance urethane bushings installed. Urethane bushings tighten up the suspension and the swivel ends allow roll deflection under cornering loads for absolutely solid, positive handling. Completely assembled and includes all new hardware.

- RC-240** 1964-66 GM A-Body rear 4-link **\$618.00**
- RC-250** 1967-72 GM A-Body rear 4-link **\$618.00**

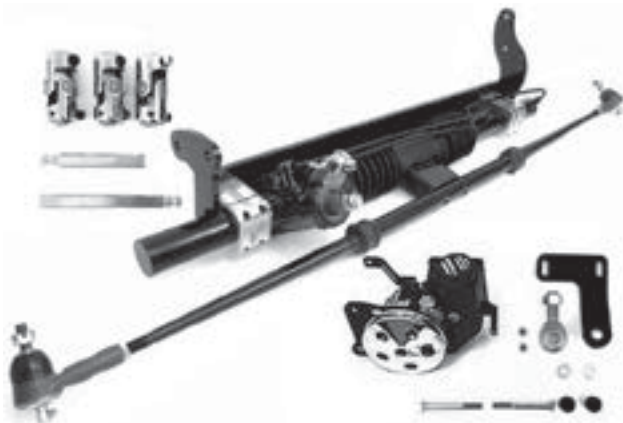

UNI-STEER POWER RACK & PINION CONVERSION

Sharpen up the lack luster steering in your classic Chevelle and A-Bodies. This rack and pinion kit greatly improves the handling and steering response, without having to chop or modify your stock frame. This kit improves the stock geometry, eliminating the bump steer found in the stock suspension. Kit is complete with pump assembly and steering shaft.

- 8010780-01** 1964-67 A-Body power rack & pinion kit . . **\$1,747.00**
- 8010740-01** 1968-72 A-Body power rack & pinion kit . . **\$1,747.00**



HEIDT'S REAR CHASSIS BRACE LINKS

These links tie the upper frame mount of the rear 4-links to the chassis crossmember to eliminate flex. They take the added stress from the new rear 4-links. Sold in pairs.

- RC-255** 1964-66 GM A-Body **\$140.00**
- RC-251** 1967-72 GM A-Body **\$140.00**

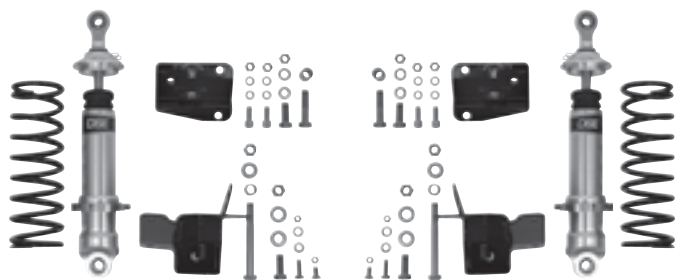

DSE REAR COIL-OVER KIT

Bolt the latest coil-over spring/shock technology to any GM A-Body. The base coil-over package offers extensive ride height adjustment and special DSE valving that will bring your classic's handling and ride into the 21st century. Optional double adjustable coil-overs offer both compression and rebound tuning. For the ultimate, use the monotube remote reservoir coil-over set with separate fluid canisters for optimum adjustability, 1" more stroke and improved heat dissipation. Kit includes, springs, shocks and brackets.

- 042410** 1964-66, A-Body. **\$1,351.95**
- 042411** 1967, A-Body. **\$1,351.95**
- 042411** 1968-72, A-Body. **\$1,351.95**

Call for pricing on shock options



DSE ALUMINUM POWER STEERING PUMP

This pump is compatible with any power steering box or rack. These are new, not remanufactured pumps. Integral black plastic reservoir is included. Available polished, in cast iron, or without the reservoir for remote fill.

- 090901** Aluminum power steering pump w/res . . . **\$276.00**
- 090301** Aluminum power steering pump w/o res . . **\$276.00**
- 090801** 6" V-belt PS pulley **\$79.00**

Call 402.886.2275 or click: www.heinzmanstreetrods.com

1964-1972 Chevelle Suspension

1964-1972 Chevelle Suspension



DSE REAR SPEED KITS

Our Speed kits are designed to provide optimum geometry and tire contact through the full range of rear suspension travel. With Swivel Links™, the rear end housing becomes fully articulated, without the use of noisy spherical heim joints. The tubular rear sway bar attaches to the chassis for a substantial improvement in cornering ability. The rear Speed Kit springs, shock absorbers and sway bars are designed to complement the front DSE Speed Kits, giving your A-Body handling and ride quality on par with the latest modern muscle cars.

Speed Kit 1: includes: patented Swivel-Link™ rear control arms and DSE chassis brace kit

Speed Kit 2: includes Kit 1, plus: DSE rear coil springs, Koni classic shock absorbers, DSE tubular rear sway bar

Speed Kit 3: includes all of the above and replaces the stock style springs and shocks with DSE specific rear coil-over shocks & springs

041603	1964-67, Speed kit 1.....	\$1,209.00
041604	1968-72, Speed kit 1	\$1,198.00
041607	1964-66, Speed kit 2.....	\$2,195.00
041609	1967, Speed Kit 2	\$2,195.00
041608	1968-72, Speed kit 2.....	\$2,195.00
041611	1964-66, Speed kit 3.....	\$2,932.00
041613	1967, Speed Kit 3	\$2,932.00
041612	1968-72, Speed kit 3.....	\$2,811.95



DSE TUBULAR REAR SWAY BAR

The DSE 1-1/8" tubular steel rear sway bar offers many advantages over the non-effective stock rear bar. DSE's bar attaches to the rear end housing and to the chassis crossmember, not the lower control arms like the OEM set-up. The DSE bar mounts to the chassis with Swivel-Links™ (Patented), eliminating binding through the range of rear suspension travel. The bar comes powder coated in a high gloss black finish and includes all necessary mounting hardware.

042201 1964-72 Rear sway bar kit..... \$403.95

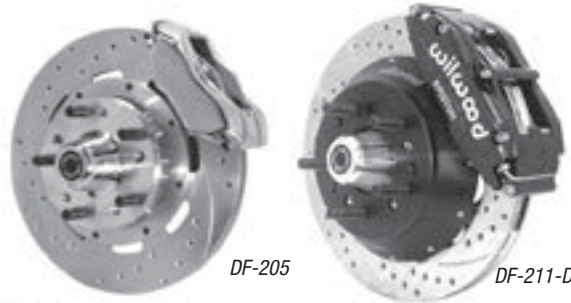

WILWOOD DISC BRAKE KITS

Four piston calipers, 11" rotors, 15" wheels, stock spindles .19" wheel offset

Use with either manual or power boost master cylinders. Kits come complete forged billet Dynalite calipers, rotors, hub assembly, brackets and hardware. Requires purchase of additional brake lines.

- 220-7056 Black anodize calipers, un-drilled rotors . \$795.00
- 220-7056 Black anodize, drilled & slotted \$1,042.00

There are many color and finish options available

Six piston calipers, 14" rotors, 18" wheels, stock spindles

The ultimate in big brakes for extreme performance and show. Manual or power boost master cylinders. Kits come complete with calipers, rotors, hub assembly, brackets and hardware.

- 140-10920-d Black anodize calipers, slotted rotors \$2,738.00
- 220-7056 Black anodize, drilled & slotted rotors . \$2,738.00

Wilwood Discs Brakes For Heidt's Dropped Spindles

- DF-205 11" drilled rotors, 4 piston polished calipers & hardware \$1,330.00
- DF-205-D 11" drilled rotors w/ polished hubs, 4 piston polished calipers & hardware .. \$1,578.00
- DF-210-D 12" drilled rotors w/ polished hubs, 4 piston polished calipers & hardware .. \$1,620.00
- DF-211-D 13" drilled rotors w/ black hubs, 4 piston black calipers & hardware . . . \$2,896.00



HEIDTS POWER BOOSTER & DUAL MASTER CYLINDER

Bolt-on kits for 1967-81 Camaros. *Kit includes:* power booster, dual master cylinder and correct proportioning valve for disc-drum or disc-disc cars. Designed for use with our Disc Brake Kits. Fully assembled and plumbed, ready for installation.

- DB-114 1964-66 A-Body booster w/mc for disc/drum . . \$299.00
- DB-114-D 1964-66 A-Body booster w/mc for disc/disc . . \$299.00
- DB-115 1967-72 A-Body manual master for disc/drum . \$175.00
- DB-115-D 1967-72 A-Body manual master for disc/disc . . \$175.00